

Please check the examination details below before entering your candidate information

Candidate surname					Other names								
Pearson Edexcel International GCSE (9–1)					Centre Number				Candidate Number				
Time 1 hour 15 minutes					Paper reference				4PH1/2P				
Physics												▲ ▲	
PAPER: 2P													
You must have: Ruler, calculator										Total Marks			

Instructions

- Use **black** ink or ball-point pen.
- **Fill in the boxes** at the top of this page with your name, centre number and candidate number.
- Answer **all** questions.
- Answer the questions in the spaces provided
– *there may be more space than you need.*
- Show all the steps in any calculations and state the units.
- Some questions must be answered with a cross in a box ☒. If you change your mind about an answer, put a line through the box ☒ and then mark your new answer with a cross ☒.

Information

- The total mark for this paper is 70.
- The marks for **each** question are shown in brackets
– *use this as a guide as to how much time to spend on each question.*

Advice

- Read each question carefully before you start to answer it.
- Write your answers neatly and in good English.
- Try to answer every question.
- Check your answers if you have time at the end.
- Good luck with your examination.

Turn over ►

P67162RA

©2021 Pearson Education Ltd.

1/1/1/1/1



Pearson

FORMULAE

You may find the following formulae useful.

energy transferred = current \times voltage \times time

$$E = I \times V \times t$$

$$\text{frequency} = \frac{1}{\text{time period}}$$

$$f = \frac{1}{T}$$

$$\text{power} = \frac{\text{work done}}{\text{time taken}}$$

$$P = \frac{W}{t}$$

$$\text{power} = \frac{\text{energy transferred}}{\text{time taken}}$$

$$P = \frac{W}{t}$$

$$\text{orbital speed} = \frac{2\pi \times \text{orbital radius}}{\text{time period}}$$

$$v = \frac{2 \times \pi \times r}{T}$$

(final speed)² = (initial speed)² + (2 \times acceleration \times distance moved)

$$v^2 = u^2 + (2 \times a \times s)$$

pressure \times volume = constant

$$p_1 \times V_1 = p_2 \times V_2$$

$$\frac{\text{pressure}}{\text{temperature}} = \text{constant}$$

$$\frac{p_1}{T_1} = \frac{p_2}{T_2}$$

$$\text{force} = \frac{\text{change in momentum}}{\text{time taken}}$$

$$F = \frac{(mv - mu)}{t}$$

$$\frac{\text{change of wavelength}}{\text{wavelength}} = \frac{\text{velocity of a galaxy}}{\text{speed of light}}$$

$$\frac{\lambda - \lambda_0}{\lambda_0} = \frac{\Delta\lambda}{\lambda_0} = \frac{v}{c}$$

change in thermal energy = mass \times specific heat capacity \times change in temperature

$$\Delta Q = m \times c \times \Delta T$$

Where necessary, assume the acceleration of free fall, $g = 10 \text{ m/s}^2$.

DO NOT WRITE IN THIS AREA

DO NOT WRITE IN THIS AREA

DO NOT WRITE IN THIS AREA



Answer ALL questions.

1 This question is about astrophysics.

(a) The table lists some statements about the universe.

Place ticks (✓) in the table to show which statements support the Big Bang theory.

(2)

Statement	Supports the Big Bang theory
black holes are formed from extremely massive stars	
cosmic microwave background radiation is detected in all directions	
cosmic rays from space are detected at the Earth's surface	
each galaxy contains billions of stars	
most galaxies show a red-shift in the light detected from them	

(b) The Sun will become a red giant star when it leaves the main sequence.

Which row correctly describes how the surface temperature and brightness of the Sun will change when it becomes a red giant?

(1)

	Surface temperature	Brightness
<input type="checkbox"/> A	decreases	decreases
<input type="checkbox"/> B	decreases	increases
<input type="checkbox"/> C	increases	decreases
<input type="checkbox"/> D	increases	increases

(c) Astronomical objects can be classified by their absolute magnitude.

State what is meant by the term **absolute magnitude**.

(2)

.....

.....

.....

.....

(Total for Question 1 = 5 marks)



- 2 The photograph shows the Three Gorges Dam in China, one of the largest hydroelectric power stations on Earth.



© PRILL/Shutterstock

- (a) State two advantages of generating electricity using hydroelectric power stations.

(2)

1

2

- (b) Water is held in a reservoir on one side of the dam.

The water flows through turbines to a river on the other side of the dam.

The water level of the river is lower than the water level of the reservoir.

- (i) State which energy store of the water decreases as the water flows from the reservoir to the river.

(1)

- (ii) How is energy transferred from the dam to homes and factories in China?

(1)

- A** by heating
- B** by radiation
- C** electrically
- D** mechanically



(c) The Three Gorges Dam has a larger maximum output power than any other hydroelectric power station on Earth.

(i) State what is meant by the term **power**.

(1)

(ii) The mean energy transferred by the dam each day is 9.7×10^{14} J.

Calculate the mean output power of the dam.

(3)

mean output power = W

(iii) The maximum output power is 22 500 MW.

Which of these is the same as 22 500 MW?

(1)

- A 22 500 000 J
- B 22 500 000 J/s
- C 22 500 000 000 J
- D 22 500 000 000 J/s

(iv) Suggest why the Three Gorges Dam does not always operate at its maximum output power.

(1)

(Total for Question 2 = 10 marks)



3 This question is about solids, liquids and gases.

(a) Melting is the process that occurs when a solid changes into a liquid.

Using ideas about particles, describe the process of melting.

(2)

.....

.....

.....

.....

.....

.....

(b) A sealed metal flask contains air at room temperature.

The flask is then heated.

The graph shows how the pressure of the air increases as its temperature increases.

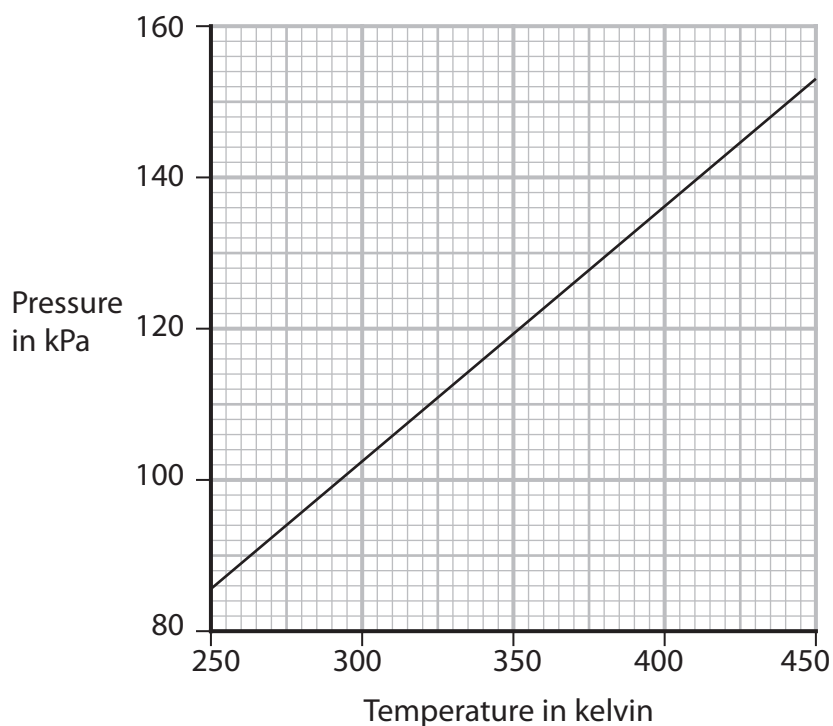

DO NOT WRITE IN THIS AREA

DO NOT WRITE IN THIS AREA

DO NOT WRITE IN THIS AREA



- (i) Explain how heating the flask increases the temperature of the air inside the flask. (2)

.....

.....

.....

.....

- (ii) Explain why the pressure of the air increases as its temperature increases. (2)

.....

.....

.....

.....

- (iii) Using the graph, determine the pressure of the air when its temperature is 400 K. (1)

pressure = kPa

- (iv) The air in the flask is now cooled to a temperature of 230 K.

Calculate the new pressure of the air.

(3)

pressure = kPa

(Total for Question 3 = 10 marks)

DO NOT WRITE IN THIS AREA

DO NOT WRITE IN THIS AREA

DO NOT WRITE IN THIS AREA



4 In extreme conditions, the isotope lithium-6 can be made to undergo nuclear fission.

- (a) The lithium-6 nucleus absorbs a neutron and produces an alpha particle and an isotope of hydrogen.

The incomplete nuclear equation for this fission is

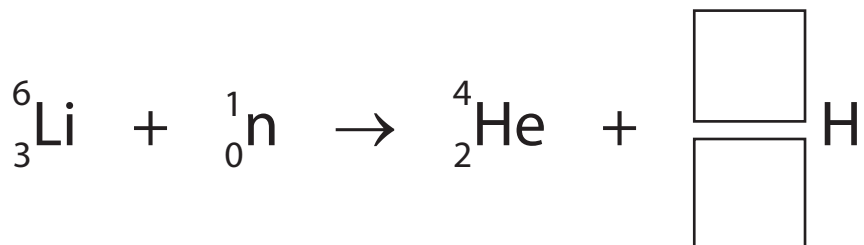

- (i) Complete the nuclear equation by writing the numbers in the boxes. (2)
- (ii) Explain why this fission does not cause a chain reaction. (2)

.....

.....

.....

.....

.....

.....

- (b) Explain the difference between nuclear fission and nuclear fusion. (2)

.....

.....

.....

.....

(Total for Question 4 = 6 marks)



- 5 A student investigates how the support forces acting on a metre rule are affected by the position of a mass hanger.

He uses this apparatus.

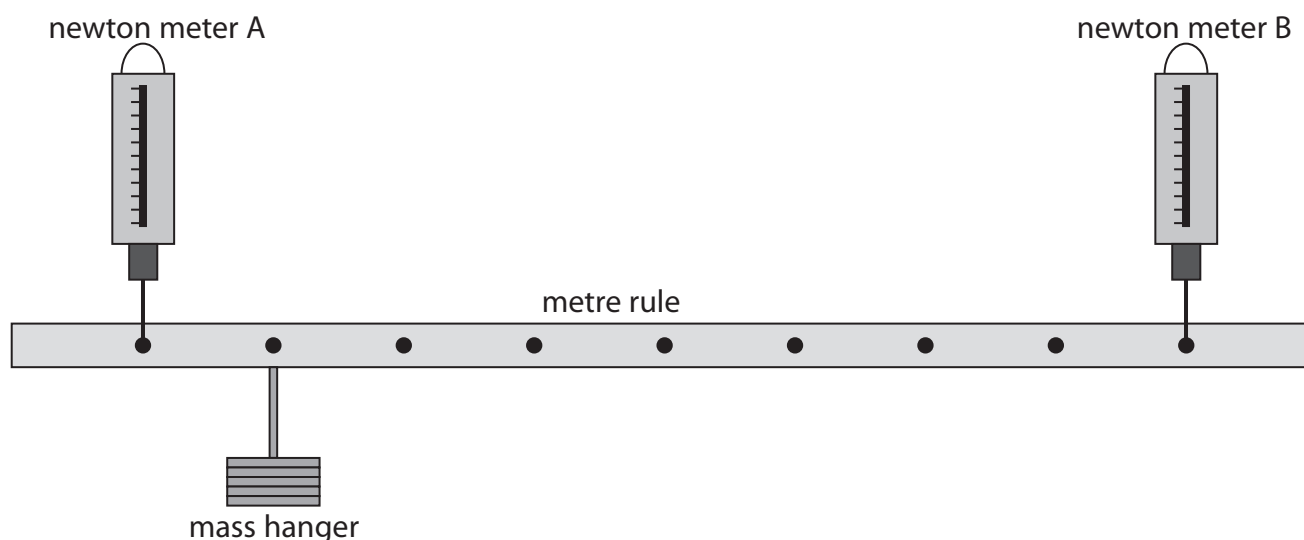

This is the student's method.

- suspend a metre rule from its 10 cm and 90 cm marks using two newton meters
- place a mass hanger with a weight of 5 N at the 20 cm mark on the metre rule
- adjust the heights of the newton meters until the metre rule is horizontal
- record the readings on both newton meters

The student repeats the method, moving the mass hanger to a different position on the metre rule each time.

- (a) (i) State the independent variable in the student's investigation.

(1)

- (ii) State two control variables in the student's investigation.

(2)

1

2

- (iii) Suggest how the student could improve the quality of his data.

(1)



(b) The table shows the student's results.

Position of mass hanger in cm	Reading on newton meter A in N	Reading on newton meter B in N
20	5.1	1.4
30	4.5	2.0
40	3.9	2.6
50	3.3	3.3
60	2.6	3.9
70	2.0	4.5
80	1.4	5.1

The graph shows the results for newton meter A.

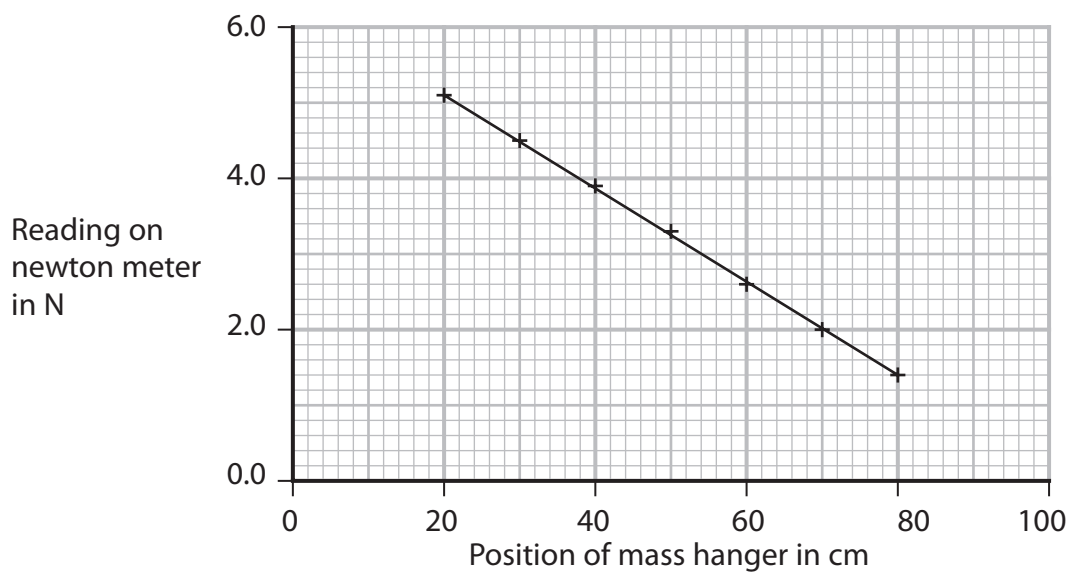

(i) Plot the results for newton meter B.

(1)

(ii) Draw the line of best fit for newton meter B.

(1)



(iii) Describe the relationships shown by the graph.

(4)

DO NOT WRITE IN THIS AREA

DO NOT WRITE IN THIS AREA

DO NOT WRITE IN THIS AREA

.....

.....

.....

.....

.....

.....

.....

.....

.....

.....

.....

.....

(c) Using ideas about moments, explain why the reading on newton meter A decreases as the mass hanger is moved towards newton meter B.

(3)

.....

.....

.....

.....

.....

.....

.....

.....

(Total for Question 5 = 13 marks)



DO NOT WRITE IN THIS AREA

DO NOT WRITE IN THIS AREA

DO NOT WRITE IN THIS AREA

BLANK PAGE



6 This question is about electromagnetism.

(a) Diagram 1 shows the construction of an electromagnet.

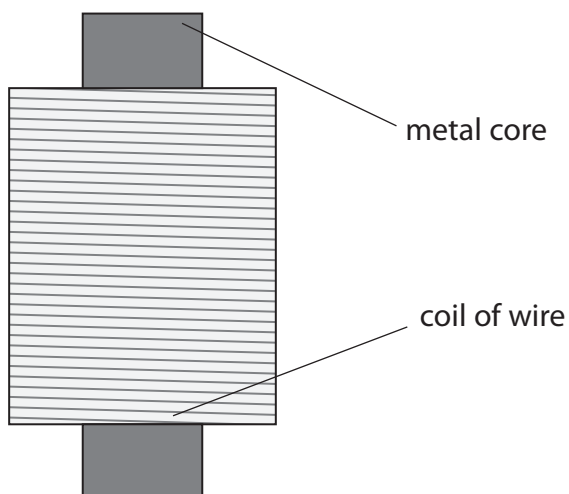

Diagram 1

(i) Name a suitable metal for the core.

(1)

(ii) State what must be done to the coil of wire to produce a magnetic field.

(1)

DO NOT WRITE IN THIS AREA

DO NOT WRITE IN THIS AREA

DO NOT WRITE IN THIS AREA



(b) Electromagnets are used in transformers to change the size of a voltage.

Diagram 2 shows the construction of a simple transformer.

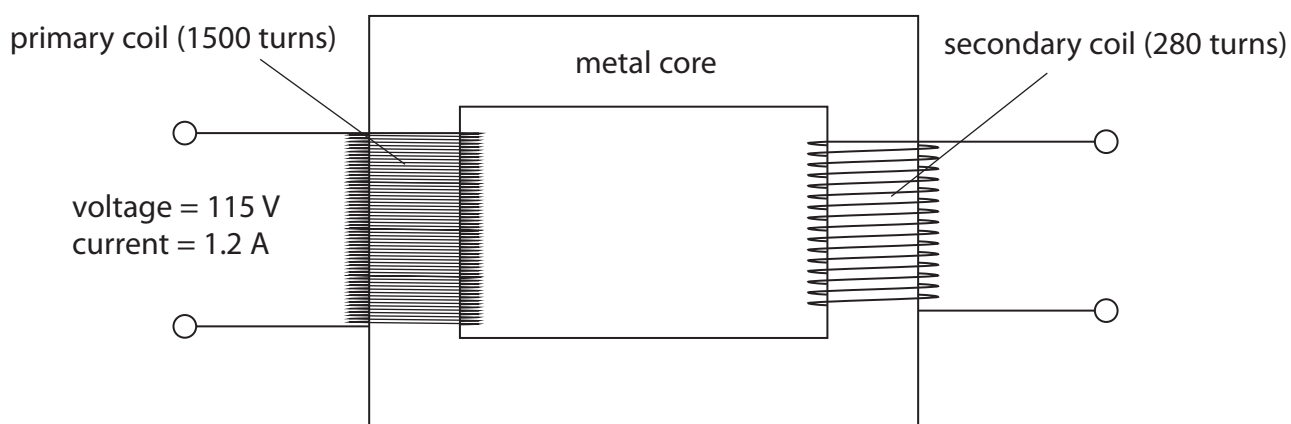

Diagram 2

(i) State the formula linking the input (primary) voltage, output (secondary) voltage and the turns ratio for a transformer.

(1)

(ii) The input voltage to the transformer is 115V.

Show that the output voltage is approximately 20V.

(3)



DO NOT WRITE IN THIS AREA

DO NOT WRITE IN THIS AREA

DO NOT WRITE IN THIS AREA

(iii) The input current to the transformer is 1.2 A.

Calculate the output current.

Assume that the transformer is 100% efficient.

(3)

output current = A

(iv) State two factors that would increase the output current of the transformer.

(2)

1

.....

2

.....

(Total for Question 6 = 11 marks)



7 An electrostatic paint sprayer is used to paint an object.

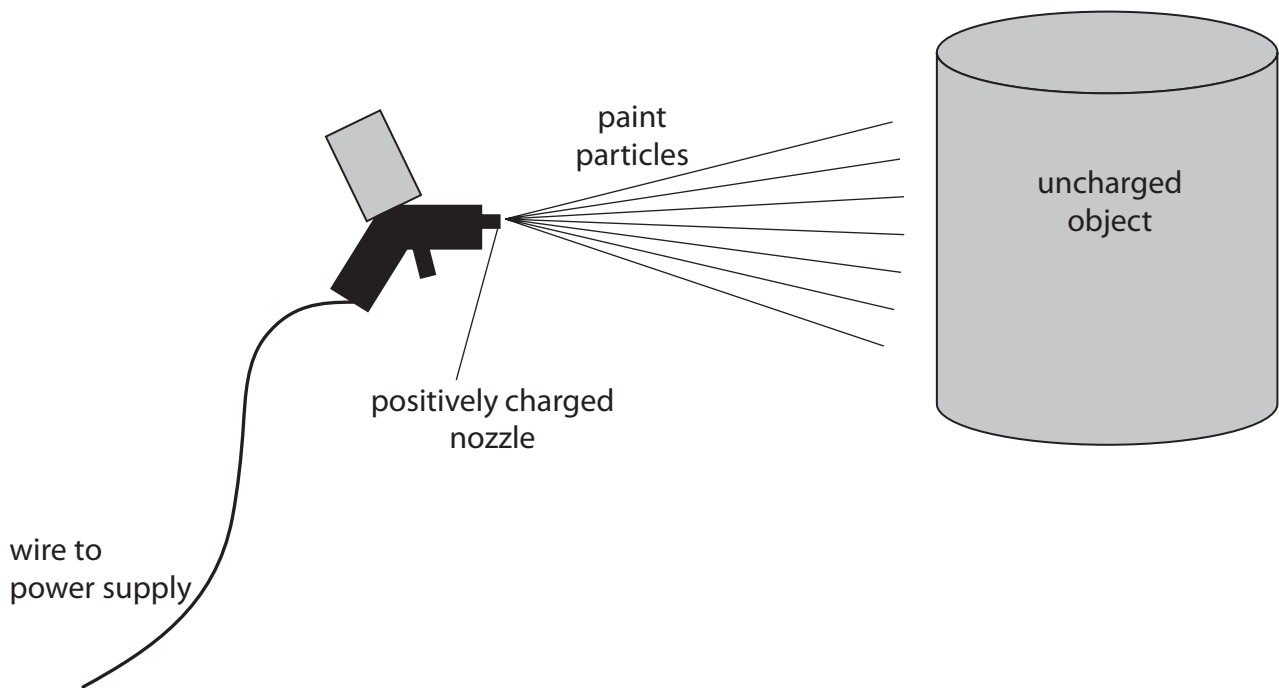

(a) The nozzle of the paint sprayer is positively charged.

Explain the advantage of using a charged nozzle.

(3)

.....

.....

.....

.....

.....

.....

DO NOT WRITE IN THIS AREA

DO NOT WRITE IN THIS AREA

DO NOT WRITE IN THIS AREA



(b) The object is an electrical conductor and is initially uncharged.

Explain why the painting process would be more effective if the object were earthed. (3)

DO NOT WRITE IN THIS AREA

DO NOT WRITE IN THIS AREA

DO NOT WRITE IN THIS AREA

(Total for Question 7 = 6 marks)



DO NOT WRITE IN THIS AREA

DO NOT WRITE IN THIS AREA

DO NOT WRITE IN THIS AREA

BLANK PAGE



8 The photograph shows an oscilloscope.



© dny3d/Shutterstock

An oscilloscope can be used to determine the frequency of a sound wave.

(a) (i) Name the piece of equipment that should be used with an oscilloscope to detect a sound wave.

(1)

(ii) Describe how an oscilloscope can be used to measure the time period of a sound wave.

(2)



(b) Diagram 1 shows an oscilloscope screen when a sound wave is detected.

It also shows the settings of the oscilloscope.

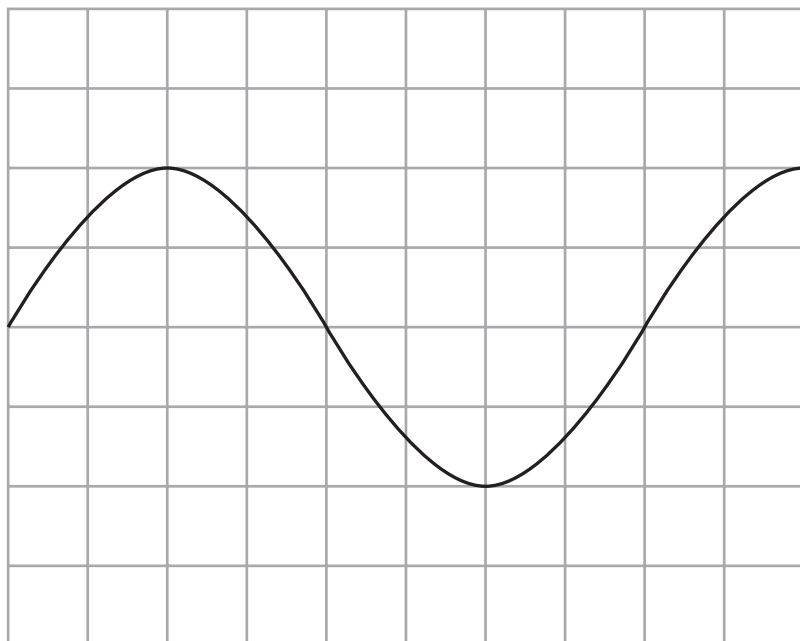

Oscilloscope settings

y direction: 1 square = 2 V

x direction: 1 square = 5×10^{-6} s

Diagram 1

(i) Determine whether the sound can be heard by humans.

Include a calculation of frequency in your answer.

(4)



(ii) The oscilloscope settings are changed, as shown in Diagram 2.

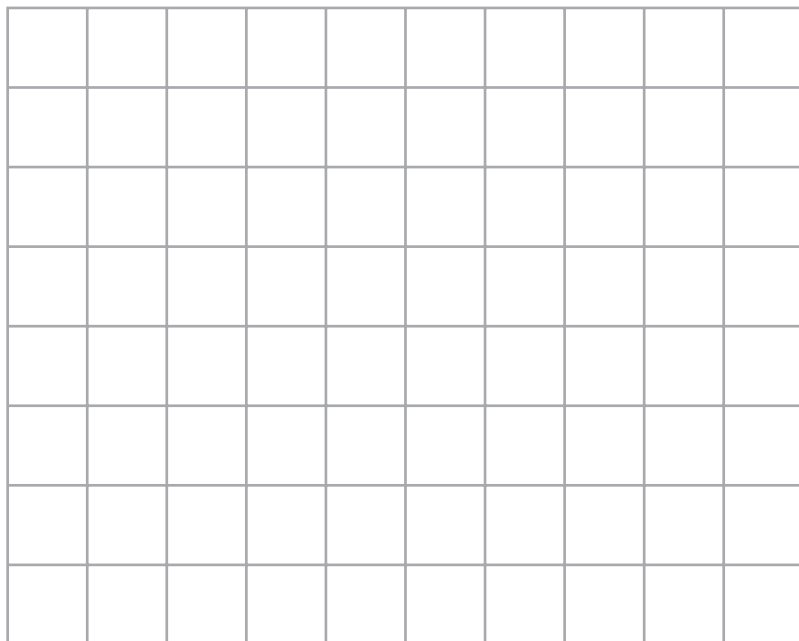

Oscilloscope settings

y direction: 1 square = 1 V
x direction: 1 square = 1×10^{-5} s

Diagram 2

On Diagram 2, draw the wave that would be displayed on the oscilloscope screen if the same sound wave is detected using these new settings.

(2)

(Total for Question 8 = 9 marks)

TOTAL FOR PAPER = 70 MARKS



DO NOT WRITE IN THIS AREA

DO NOT WRITE IN THIS AREA

DO NOT WRITE IN THIS AREA

BLANK PAGE



DO NOT WRITE IN THIS AREA

DO NOT WRITE IN THIS AREA

DO NOT WRITE IN THIS AREA

BLANK PAGE



DO NOT WRITE IN THIS AREA

DO NOT WRITE IN THIS AREA

DO NOT WRITE IN THIS AREA

BLANK PAGE

